

mech fiber



Keenan[™]
True Technology

A Profit Plan

for your Business and your Bank Manager





+ 10%

increase in Feed Conversion Efficiency in just one year, producing 40kg/cow/year more milk solids worth €145/cow/year.

+ 30%

higher Feed Conversion Efficiency for top 25% of users giving 120kg/cow/year more milk solids worth an extra €425/cow/year.

Mech-fiber™ is a true breakthrough in dairy and beef feeding.

At the heart of the approach is the patent protected Keenan Mech-fiber™ mixing-processing design.

Based around the unique 'bird's nest' physical ration form produced in Keenan feeders, Mech-fiber™ delivers improved digestibility in the rumen, allowing cattle to extract more nutrients from their feeds and produce more milk or beef from every pound or kilo of feed intake.

A direct result of the Keenan's gentle mixing and processing action that moves all of the feed material all of the time, Mech-fiber™ has been proven to reduce feed wastage, improve feed conversion efficiency and drive margin gain.

The consistency of these gains across scientific research, field trials and on farms throughout the world is truly compelling, highlighting the very real opportunity for all dairy and beef farmers to significantly improve their efficiency and profits – rapidly.

With cows at pasture, feeding Keenan Mech-fiber™ grazing rations improves both rumen function and biological activity, allowing more nutrients and energy to be extracted from the grass and supplementary feeds. In addition, consumed grass is retained longer in the rumen producing more milk and milk solids from every kg of dry matter consumed. Grass intakes are maintained, feed efficiency is improved and milk response to the Keenan ration is optimised.

Indeed, a recent field study of 1100 herds in a housed environment has shown the approach to deliver a 10% increase in Feed Conversion Efficiency in just one year.

Keenan's target gain in milk solids production is 40kg per cow and that's worth an extra €145/cow within 12 months in Ireland.

There's major long-term gains too. In fact, Keenan's top 25% of customers globally are achieving lifts of 30% in feed conversion efficiency – equivalent to an extra 120kg of milk solids/cow/year worth a net gain of €425/cow in Ireland.



Improving Feed Conversion Efficiency with Mech-fiber™ can deliver major improvements in profitability

Using the Mech-fiber™ approach to lift feed conversion efficiency is one of the most reliable and dramatic ways you can lift your overall enterprise profitability.

The average improvement in Feed Conversion with Mech-fiber™ is 10% within the first year. Given that the top 25% of Keenan customers have feed efficiency levels 30% above the average, it's clear the potential for improvement is substantial over 2-3 years. It's worth looking at what these figures mean in real money.

Professor David Colman, President of the International Association of Agricultural Economists, explains that if nothing else changes and you improve FCE you improve profit.

For a 7000 litre herd with an average Feed Conversion Efficiency of 1.15 (ie 1.15kg milk per kg dry matter intake) and with a milk price of 22c/litre, total milk revenue is €1540 and profit per cow would be €154. Improving feed efficiency by 10% - remember the Keenan first year average is 10% - puts net margin up to €308 per cow per lactation simply by producing more milk from the same feed. That's an 100% gain in profitability – and that's assuming you were making a 10% margin in the first place!

Impact of 10% increase in Feed Efficiency

	FCE	+ 10% FCE	GAIN
Milk Output (litres)	7000	7700	700
Milk Revenue (cow/year)	€1540	€1694	€154
Overall costs (cow/year)	€1386	€1386	0
Profit - Net (cow/year)	€154	€308	€154



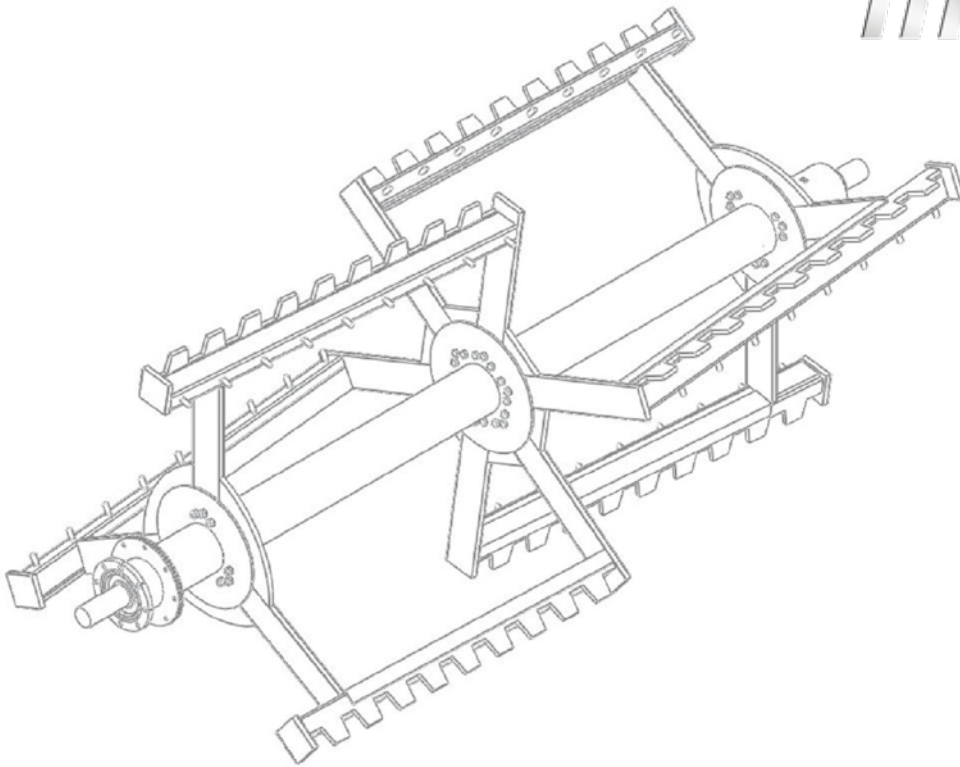

In designing the new range of Keenan Mech-fiber™ feeders, our engineers didn't just set out to design the best on-farm mixer/processor, they were focused on delivering the optimum ration structure to drive feed conversion efficiency.

Based on legendary Keenan reliability, Mech-fiber™ feeders bring together simplicity of operation with the most sophisticated mechanical and electronic engineering.

At any one moment in time, a variety of functions are in effect being carried out to produce the optimum Mech-fiber™ ration form to deliver the highest feed conversion efficiency.

For a start, a specially developed mixing chamber profile, carbon steel knives and castellated paddles condition and process feed and forage materials to provide precisely the right fibre base for the ration.

At the same time, the feeder's trademark low energy, non-aggressive mixing action gently tumbles and mixes all materials, preserving their structural integrity without over-processing whilst producing the optimum open, low density Mech-fiber™ mix with an even distribution of all materials through it.

If you thought all mixers were the same, think again.

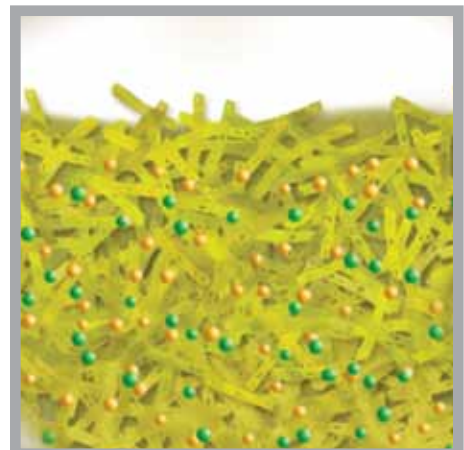
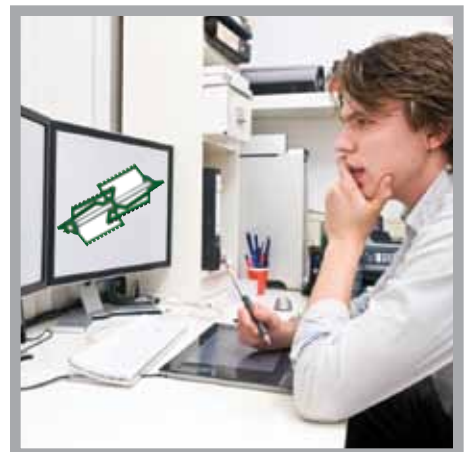

The starting point for bringing the benefits of Mech-fiber™ to your enterprise is the Keenan Mech-fiber™ feeder. Available in a range of sizes to suit every livestock enterprise from small dairy units to large-scale beef operations, Mech-fiber™ feeders feature integrated Mech-fiber™ mixing and processing technology to deliver high outputs of the optimum ration structure to drive feed efficiency and margins.

High volume mixing capacity

Mech-fiber™ feeders feature high volume mixing chambers with a unique profile that extends deep into the chassis. This design means Mech-fiber™ feeders can not only feed more animals, there's also more space for the vital 'light touch' tumbling action for non-destructive ration preparation.



Unique paddle and knife configuration

With six angled paddles featuring castellated blades, Mech-fiber™ mixing is a low stress operation. Rotating at just 7rpm, the paddle works seamlessly with precision engineered knives throughout the feeder to produce the perfect physical base for Mech-fiber™ rations quickly and consistently.



Small load capability

In Mech-fiber™ feeders, all material is moving all of the time with no dead spots. As well as superior ration preparation, this unique feature means Mech-fiber™ feeders can process loads from as little as 500kg.



Separate mixing and feed-out chambers

Mech-fiber™ feeders have a separate feed-out chamber with a high performance auger for clean, efficient feed-out. Driven at high speed, this design has the added advantage of rapid feed-out time. In addition, the variable feed control door allows simple regulation of feed-out and the facility to add ingredients to the mix part way through a load.

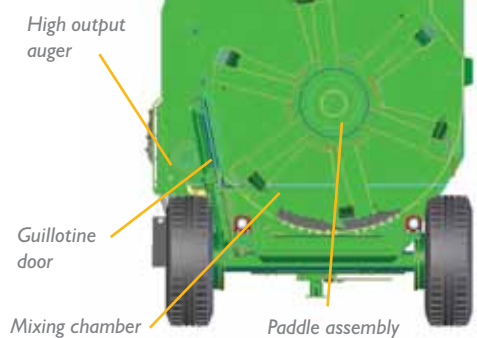



Lower power, torque and fuel requirements

Controlled chopping speed significantly reduces torque requirements. For example a Mech-fiber™ 320 requires only a 90 HP tractor, resulting in dramatic savings on overall fuel consumption compared with other mixers.

All Mech-fiber™ feeders are precision engineered in state of the art manufacturing facilities. This combined with their peerless design, gives many years of trouble free service.

In addition, Mech-fiber™ feeders can be custom made to suit virtually any farm set-up.



Effortless and rapid big bale processing

Baleblend™ is exciting new technology from Keenan that allows Mech-fiber™ feeders to be able to handle whole bales of forage with precision and speed.

In keeping with Keenan's low energy approach to keeping vital forage structures intact, Baleblend™ effortlessly incorporates big round and square bales - silage, hay or straw - into the Mech-fiber™ mix without damaging the core fibre or over-processing dry material.

Precision engineered concentric rings with a unique profile, support the heaviest of bales on the machines paddle structure, feeding material in measured quantities on to the feeder's top knife where its is drawn down into the feeders mixing chamber.

From there, the castellated paddles and carbon fibre knives process the forage into exactly the right Mech-fiber™ base along with the other feed materials.

All Mech-fiber™ feeders can be supplied with the new Baleblend™ bale chopping technology.

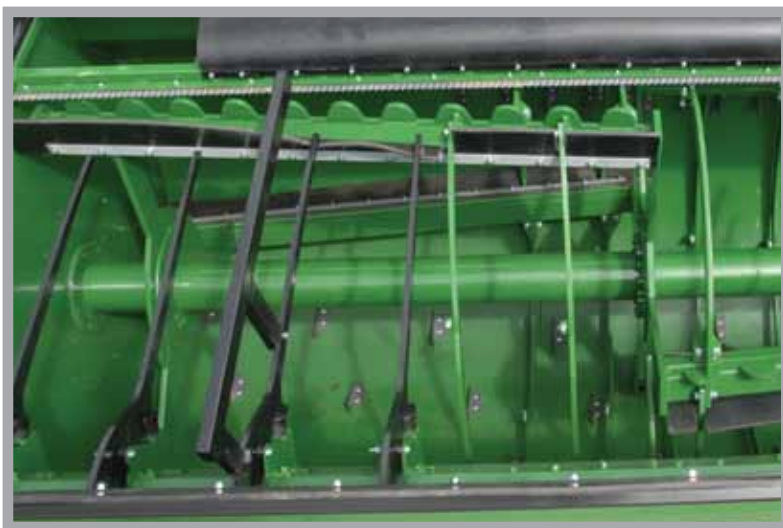
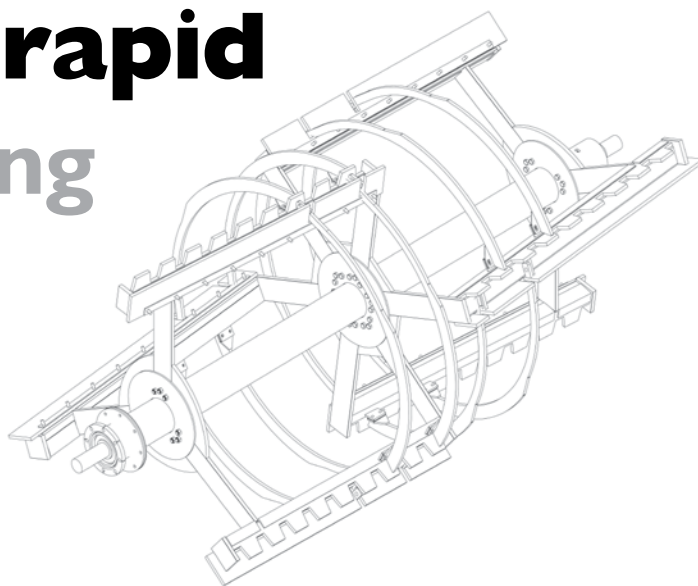

Going, going, gone in 90 seconds

Baleblend™ turns the Mech-fiber™ feeder into a truly versatile feed processor allowing it to handle virtually any feed constituent imaginable. Like standard Mech-fiber™ feeders, Baleblend™ feeders mix, process and chop all feed materials into perfectly structured rations for optimum digestibility and rumen performance, but in addition they can process big bales in a matter of seconds. The frames below took just 90 seconds to shoot.



mech fiber™ PACE

With PACE - Performance Acceleration and Control Enhancement - Keenan has introduced another world first to help producers create precise and consistent Mech-fiber™ rations on-farm.

PACE allows the production, economic and herd health benefits to be achieved consistently and reliably in a variety of farming situations, with a range of feeds and forages, anywhere in the world.

At its heart is the Keenan's Mech-fiber™ PACE control unit that links our knowledge of how to maximise the impact of Mech-fiber™ directly to your farm and your Keenan.

Based on each farm's individual ration requirements, PACE links web-based technology, farm computer and mixer to allow operators to produce the perfect Mech-fiber™ ration, day in day out, through precise management of ingredient loading sequence and mixing times.

Furthermore, information can be transferred back from the machine's PACE control unit to Keenan via the internet, to generate critical performance reports, including Feed Conversion Efficiency and Margins, to ensure farm performance keeps up with the best national and international producers.



PACE gives you the full picture of your herd's performance by linking together Keenan's powerful web-based knowledge store directly with your dairy or beef enterprise so you can produce the perfect Mech-fiber™ ration for your herd. As well as managing all elements of ration production you can also download data from your feeder to the PACE website for rapid performance reports to help you maximise Feed Conversion Efficiency and Margins.



As a PACE user, you're part of a unique global community of dairy and beef producers with access to powerful resources to help you maximise production efficiency, margins and profits.

Every PACE user has exclusive access to a sophisticated Mech-fiber™ community website that not only allows them to chart their own progress with regard to Feed Conversion Efficiency and margin gains, but also let's them benchmark their performance against other users, both nationally and internationally.

Every time an individual record is updated, no matter where it is in the world, the whole community is updated giving a dynamic and up-to-the-minute picture of Mech-fiber™ performance globally.

At an individual level, you can trace your own feeds or ration used, output produced, feed costs incurred and margin improvements gained. All with the focus on helping you maximise performance and profits.

In addition, you can download information, videos and publications on how to get more from your business and your cows as well as taking part in state of the art on-line webinars on best practice. It's another Keenan world first.



Providing excellence in customer service, be it in terms of helping you achieve higher performance or ensuring you have the best after-sales and machinery back-up, lies at the very heart of the Keenan philosophy.

As a manufacturer of mixer-feeders, we have set the standard in machine performance, reliability and service support for many years. All our equipment is built to deliver outstanding results and last for many years. Whenever you need support, professional and rapid help is but a phone call away.

As a technology leader, we are equally committed to forging new ways of improving the practice of livestock feeding, harnessing the power of new communication routes and developing 'world class' practices across the whole spectrum of our operation.



Richard Keenan & Co. Ltd.

Borris, Co. Carlow, Ireland

Tel: +353 (0) 59 977 1200

Tel: +44 (0) 24 7669 8200 (NI)

www.keenansystem.com

Keenan  TM
True Technology